

Giant Fountains Dramatic Displays



When you want to create a bold impression look to any of the patterns found within Otterbine's Giant Fountain line. Often specified by landscape architects and designers, these floating fountains create sensational displays wherever they are found.

Premier locations throughout the world, from resorts and country clubs to corporate headquarters, select these systems because of their beauty, versatility and quality. From the staggering 90ft or 27m height of



“Otterbine was very helpful in the design and specification aspects of our water feature project. A company representative did a site inspection and helped with a product recommendation and design within days of our inquiry.”

**—Richard H. Brooks,
Brooks Development Group**

our Super Nova to the magnificent multi-dimensional cascading pattern of the Equinox—onlookers are mesmerized by the magnificence of these fountains.

Constructed for ease of use, the Giant Fountain line allows for shallow operating depths of only 40in or 1m, while large wheels on the frame improves mobility eliminating the need for hoists and cranes in most instances. Combine this with corrosion resistant materials, a unique screening system to simplify cleaning and an adjustable float to minimize visibility in the water—these units are virtually maintenance free. Better

yet they are backed by an all-inclusive 4-year warranty that can be increased to a 5-year warranty when purchased with power monitoring Subtrols.

Prolong the beauty of a Giant Fountain with the addition of our Fountain Glo™ light systems. From our energy efficient LED lights to our color changing Maxi-RGBW sequencing light systems, create awe-inspiring displays to further captivate from day into night.

Specifications and CAD drawings can be found through our website at www.otterbine.com/specs.



TRIAD

60 Hz	10HP	15HP	25HP
Spray Height (ft)	36	40	50
Spray Diameter (ft)	33	37	42
GPM	300	390	500
50 Hz	10HP	15HP	25HP
Spray Height (m)	10.4	11.6	14.3
Spray Diameter (m)	9.4	10.7	12.2
m ³ /hr	68.1	88.5	113.5



EQUINOX

60 Hz	10HP	15HP	25HP
Spray Height (ft)	28	31	41
Spray Diameter (ft)	80	85	106
GPM	300	390	500
50 Hz	10HP	15HP	25HP
Spray Height (m)	8	9	12
Spray Diameter (m)	24	25	32
m ³ /hr	68	88	113



AQUASTAR

60 Hz	10HP	15HP	25HP
Spray Height (ft)	36	40	50
Spray Diameter (ft)	33	37	42
GPM	225	350	400
50 Hz	10HP	15HP	25HP
Spray Height (m)	10.4	11.6	14.3
Spray Diameter (m)	9.4	10.7	12.2
m ³ /hr	51.1	79.5	90.8



MYSTIC

60 Hz	10HP	15HP	25HP
Spray Height (ft)	40	50	65
Spray Diameter (ft)	6	6	6
GPM	450	500	800
50 Hz	10HP	15HP	25HP
Spray Height (m)	11.6	14.3	18.9
Spray Diameter (m)	1.8	1.8	1.8
m ³ /hr	102.2	113.5	181.6



SUPERNOVA

60 Hz	10HP	15HP	25HP
Spray Height (ft)	55	70	95
Spray Diameter (ft)	1	1	1
GPM	225	350	400
50 Hz	10HP	15HP	25HP
Spray Height (m)	15.8	20.1	27.4
Spray Diameter (cm)	30	30	30
m ³ /hr	51.1	79.5	90.8

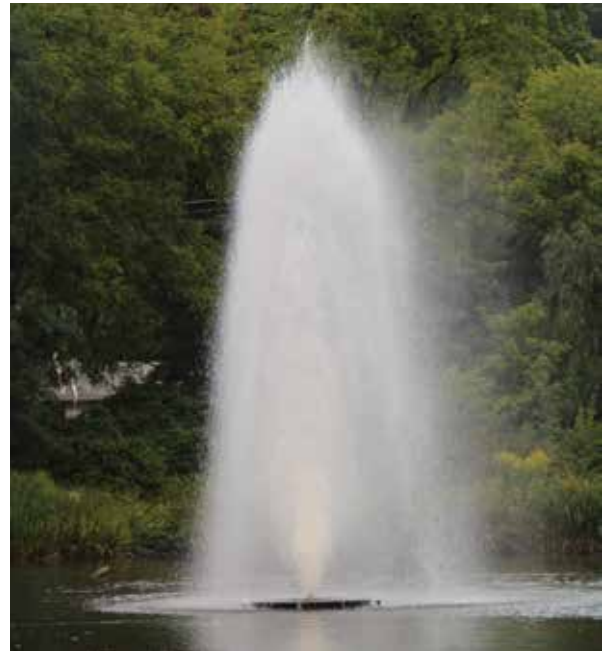

POLARIS

60 Hz	10HP	15HP	25HP
Spray Height (ft)	27	30	35
Spray Diameter (ft)	13	8	8
GPM	675	750	1,200
50 Hz	10HP	15HP	25HP
Spray Height (m)	7	8.5	10.1
Spray Diameter (m)	2.4	2.4	2.4
m ³ /hr	153.2	170.3	272.4



ARIES

60 Hz	10HP	15HP	25HP
Spray Height (ft)	27	30	37
Spray Diameter (ft)	85	101	121
GPM	300	390	500
50 Hz	10HP	15HP	25HP
Spray Height (m)	7	8	10
Spray Diameter (m)	24	28	33
m ³ /hr	68	88	113

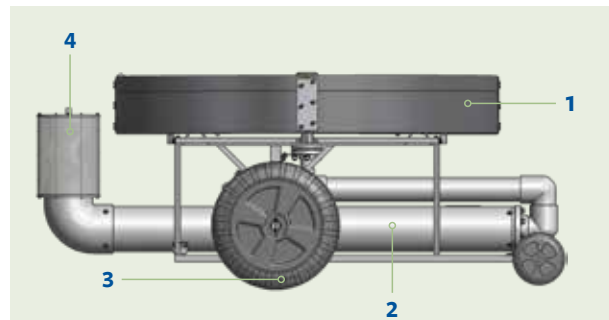

PRODUCT ILLUSTRATION

- 1 Special polyethylene float allows for easy height adjustment to make it less visible in the water.
- 2 High quality Grundfos pump and Franklin 3450/2875 RPM motor ensure years of corrosion-resistant, trouble-free run time and no maintenance.
- 3 Large center wheels assist installation and removal eliminating the need for a crane in most applications.
- 4 Removable stainless steel intake screen allows for cleaning in the water and protects pump from debris.

Complete package is safety tested, approved and listed with ETL. Products for the European Union are also safety tested, approved, and carry CE certification. Minimum operating depth is 40in or 1m, with and without lights. See www.otterbine.com for product testing and package details.